

22. LIGHTS/METERS/SWITCHES

SYSTEM LOCATION.....	22-2	FUEL RESERVE SENSOR	22-17
SERVICE INFORMATION	22-3	OIL PRESSURE INDICATOR	22-19
HEADLIGHT	22-5	IGNITION SWITCH.....	22-20
TURN SIGNAL LIGHT.....	22-8	HANDLEBAR SWITCH.....	22-21
BRAKE/TAIL LIGHT.....	22-9	BRAKE LIGHT SWITCH	22-22
LICENSE LIGHT	22-10	CLUTCH SWITCH.....	22-23
SPEEDOMETER.....	22-10	NEUTRAL SWITCH	22-24
VS SENSOR	22-14	SIDESTAND SWITCH.....	22-25
COOLANT TEMPERATURE INDICATOR /ECT SENSOR.....	22-16	HORN	22-26
		TURN SIGNAL RELAY	22-27

LIGHTS/METERS/SWITCHES
SYSTEM LOCATION

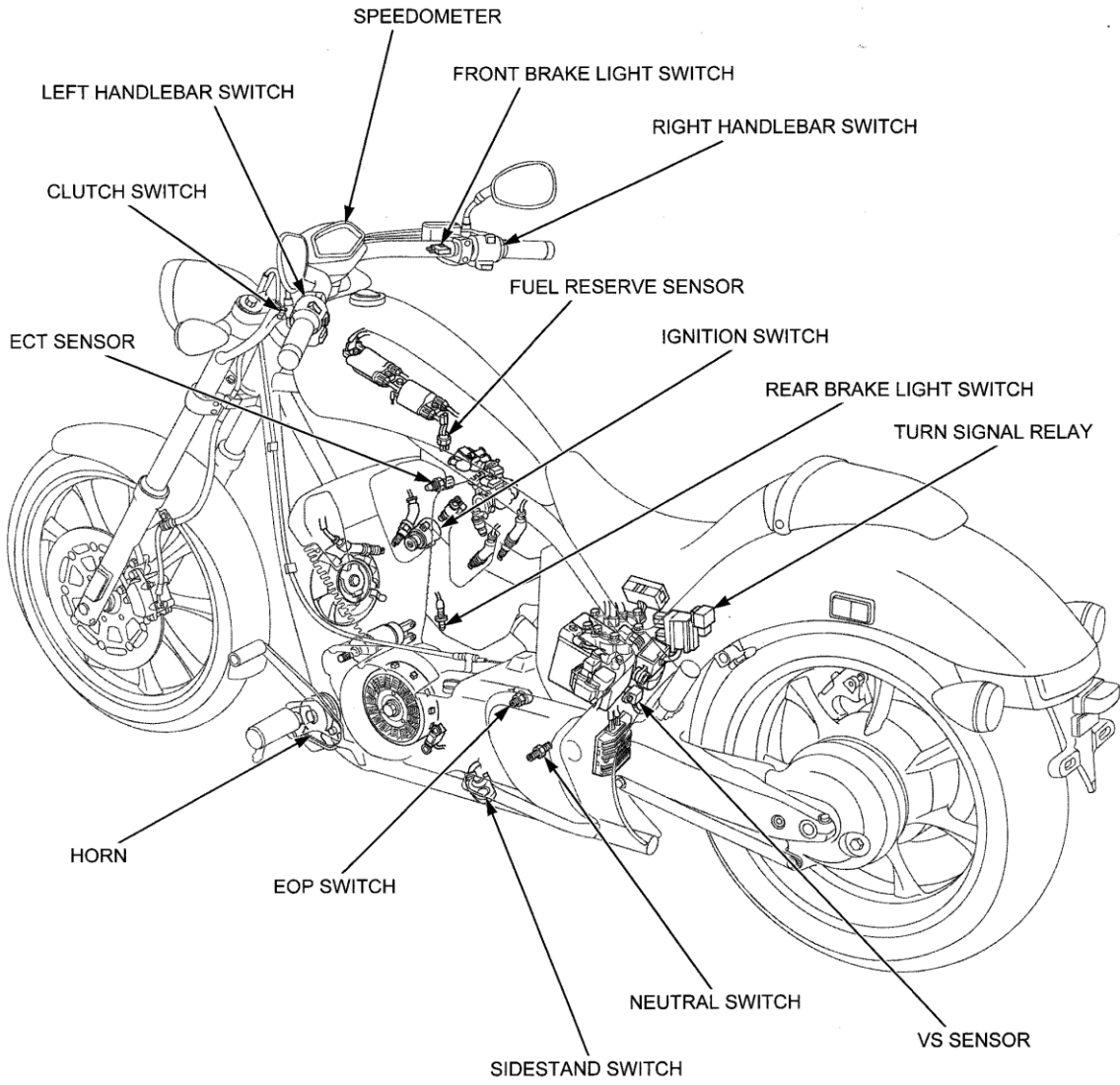

SERVICE INFORMATION

GENERAL

NOTICE

- Note the following when replacing the halogen headlight bulb.
 - Wear clean gloves while replacing the bulb. Do not put fingerprints on the headlight bulb, as they may create hot spots on the bulb and cause it to break.
 - If you touch the bulb with your bare hands, clean it with a cloth moistened with alcohol to prevent its early failure.
- A halogen headlight bulb becomes very hot while the headlight is on, and remains hot for a while after it is turned off. Be sure to let it cool down before servicing.
- Be sure to install the dust cover after replacing the headlight bulb
- Use an electric heating element to heat the water/coolant mixture for the instrumentation ECT switch inspection. Keep all flammable materials away from the electric heating element. Wear protective clothing, insulated gloves and eye protection.
- Check the battery condition before performing any inspection that requires proper battery voltage.
- A continuity test can be made with the switches installed on the motorcycle.
- The following color codes used are indicated throughout this section.

Br = Brown G = Green Lg = Light Green W = White
 Bl = Black Gr = Gray O = Orange Y = Yellow
 Bu = Blue Lb = Light Blue R = Red

SPECIFICATIONS

ITEM		SPECIFICATIONS
Bulbs	Headlight	12 V – 60/55 W
	Brake/tail light	LED
	License light	12 V – 5 W
	Front turn signal/position light	12 V – 21/5 W x 2
	Rear turn signal light	12 V – 21 W x 2
	Instrument light	LED
	Turn signal indicator	LED
	High beam indicator	LED
	Fuel reserve indicator	LED
	Neutral indicator	LED
	Engine oil pressure indicator	LED
	Coolant temperature indicator	LED
	MIL	LED
	ABS indicator (VT1300CXA)	LED
Fuse	Main fuse	30 A
	Sub fuse	10 A x 5, 20 A x 2
	ABS fuse (VT1300CXA)	30 A x 2, 10 A x 1

TORQUE VALUES

Turn signal light lens screw	1 N·m (0.1 kgf·m, 0.7 lbf·ft)	
Brake/tail light mounting bolt	5.2 N·m (0.5 kgf·m, 3.8 lbf·ft)	
License light lens screw	1 N·m (0.1 kgf·m, 0.7 lbf·ft)	
License light mounting nut	4.5 N·m (0.5 kgf·m, 3.3 lbf·ft)	
Speedometer upper cover screw	1 N·m (0.1 kgf·m, 0.7 lbf·ft)	
Ignition switch mounting torx bolt	10 N·m (1.0 kgf·m, 7 lbf·ft)	
Neutral switch	12 N·m (1.2 kgf·m, 9 lbf·ft)	
Sidestand switch bolt	10 N·m (1.0 kgf·m, 7 lbf·ft)	ALOC bolt; replace with a new one.
VS sensor mounting bolt	10 N·m (1.0 kgf·m, 7 lbf·ft)	
Fuel reserve sensor	23 N·m (2.3 kgf·m, 17 lbf·ft)	
Horn mounting bolt	27 N·m (2.8 kgf·m, 20 lbf·ft)	
EOP switch terminal screw	2.2 N·m (0.2 kgf·m, 1.6 lbf·ft)	

LIGHTS/METERS/SWITCHES

TOOL

Test probe
07ZAJ-RDJA110

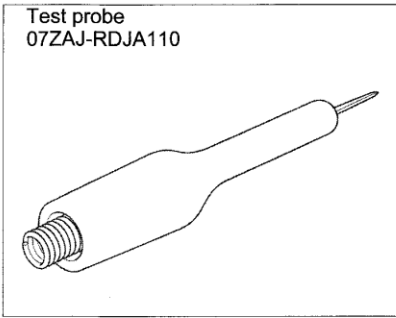

HEADLIGHT

BULB REPLACEMENT

Remove the socket bolt and headlight rim while releasing rim slots from the headlight case tabs.

Remove the socket bolts and the headlight unit by releasing headlight unit grommet from the headlight case tab.

Disconnect the headlight 3P (Natural) connector.

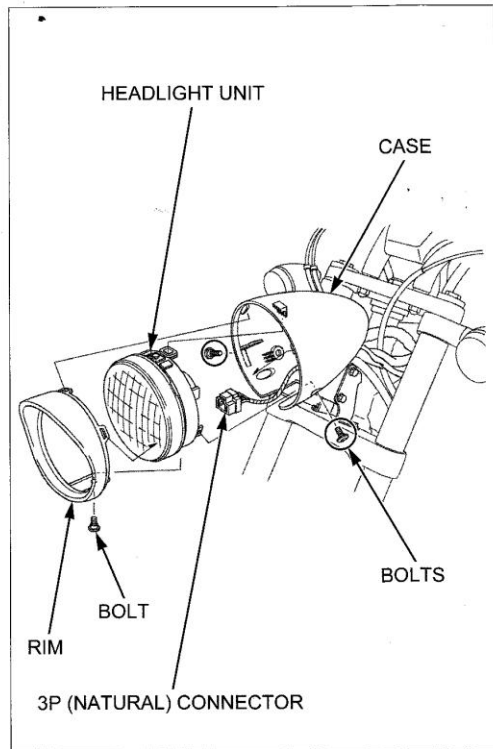

Remove the dust cover.

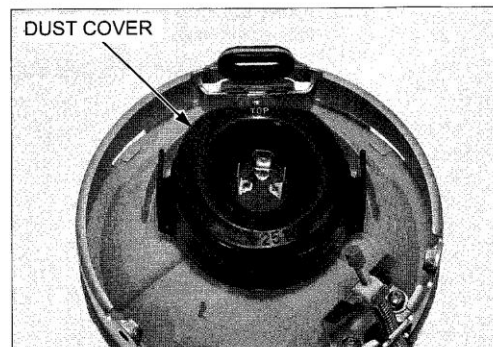

Unhook the bulb retainer.

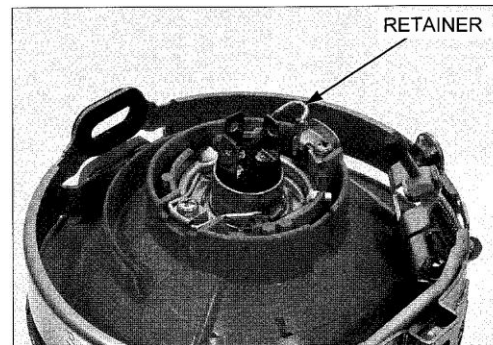

LIGHTS/METERS/SWITCHES

Remove the bulb and replace it with a new one.

NOTICE

Avoid touching the halogen headlight bulb. Fingerprints can create hot spots that cause a bulb to break.

Hook the bulb retainer properly.

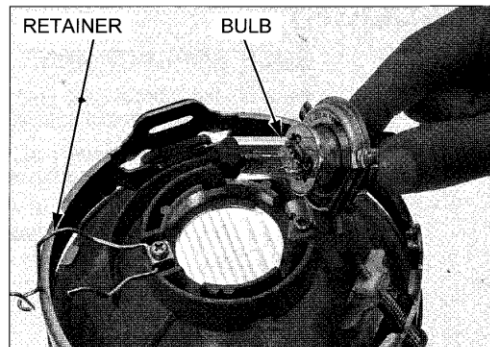

Install the dust cover properly onto the headlight with the "TOP" mark facing up.

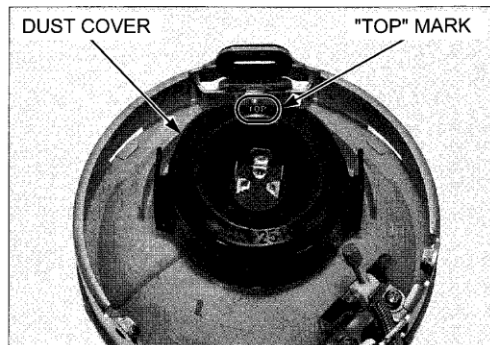

Connect the headlight 3P (Natural) connector.

Install the headlight unit into the case by aligning its grommet with the tab in the case.

Install and tighten the socket bolts.

Install the headlight rim by aligning its slots with the tabs of the case.

Install and tighten the socket bolt.

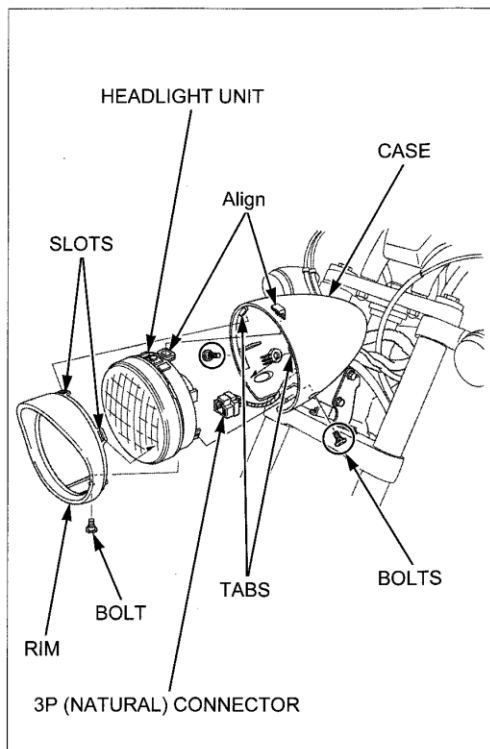

**HEADLIGHT CASE REMOVAL/
INSTALLATION**

Remove the headlight unit (page 22-5).

Release the wire harnesses from the clamps and disconnect the following:

- Speedometer sub harness 7P (Green) connectors
- Front turn signal light 3P connectors

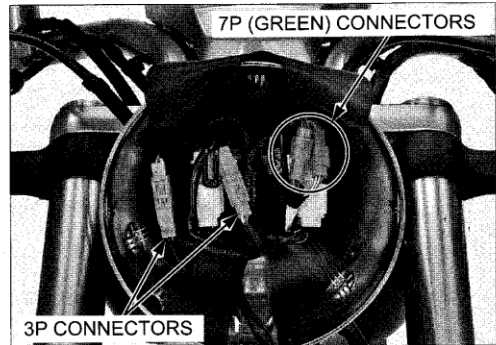

Remove the screws and stay.

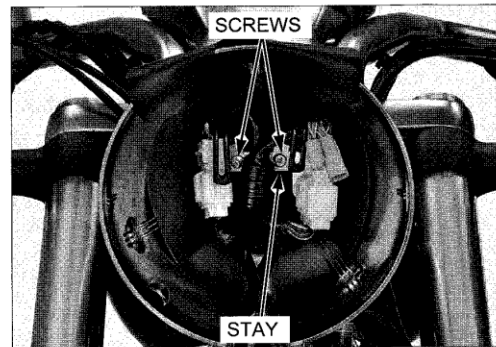

Remove the stay by disconnecting the clamps of the handlebar switch connectors.

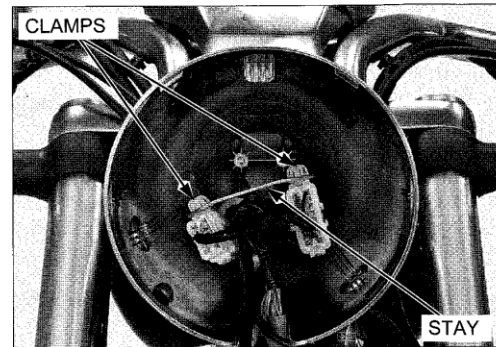

Remove the headlight case mounting bolts, nuts and headlight case.

Route the wire harnesses properly (page 1-22).

Installation is in the reverse order of removal.

NOTE:

- When installing the headlight case, tighten the headlight mounting nuts in several steps alternately.

Adjust the headlight aim (page 4-24).

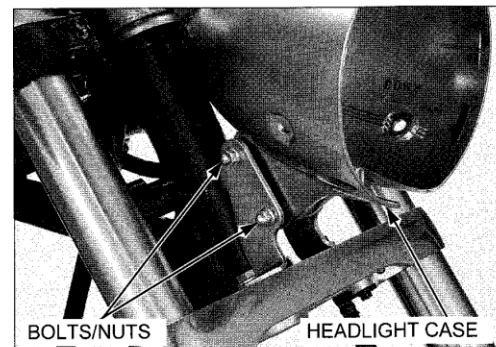

TURN SIGNAL LIGHT

BULB REPLACEMENT

Remove the screw and turn signal light lens.

While pushing the bulb in, turn it counterclockwise to remove it, and replace it with a new one.

Make sure the lens packing is installed in position and is in good condition, and replace it with a new one if necessary.

Install the lens, aligning the slot with the tab of the turn signal light.

Install and tighten the screw to the specified torque.

TORQUE: 1 N·m (0.1 kgf·m, 0.7 lbf·ft)

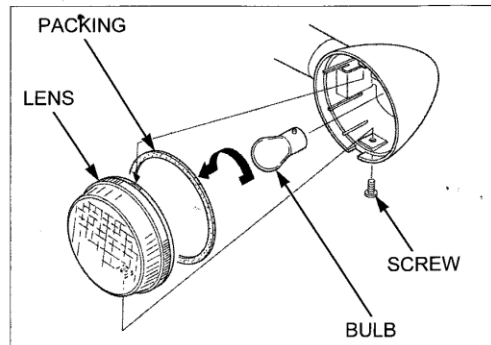

REMOVAL/INSTALLATION

FRONT

Remove the headlight unit (page 22-5).

Disconnect the turn signal light 3P connectors.

NOTE:

- Light blue: Right turn signal light connector
- Orange: Left turn signal light connector

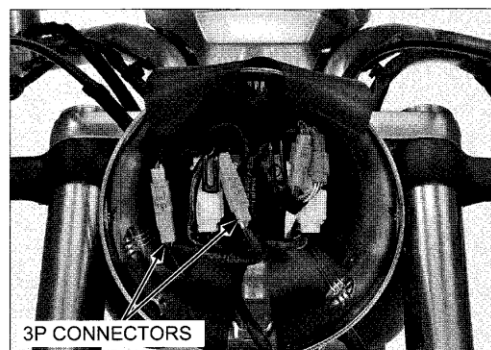

Release the wire from the clamp and remove it out of the headlight case.

Remove the following:

- Bolt
- Nut
- Stopper plate
- Turn signal light

Route the turn signal wire properly (page 1-22).

Installation is in the reverse order of removal.

NOTE:

- Align the stopper plate into the slit in the fork top bridge.

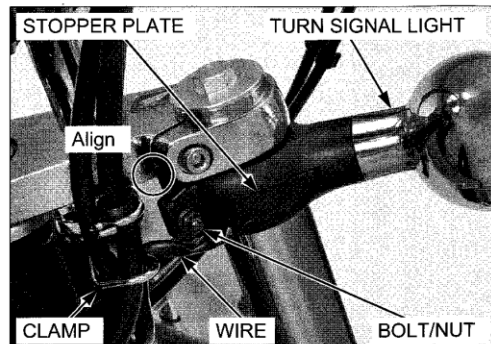

REAR

Remove the rear fender (page 3-8).

Disconnect the turn signal light 2P connectors.

Release the turn signal light wires from the holes of the rear fender A.

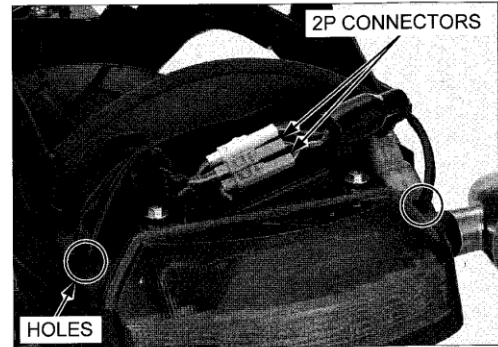

Remove the mounting bolt and turn signal light while releasing the turn signal wire from the rear fender A stay.

Align the turn signal light tab and hole of the rear fender A stay.

Installation is in the reverse order of removal.

NOTE:

- Route the wires properly (page 1-22).

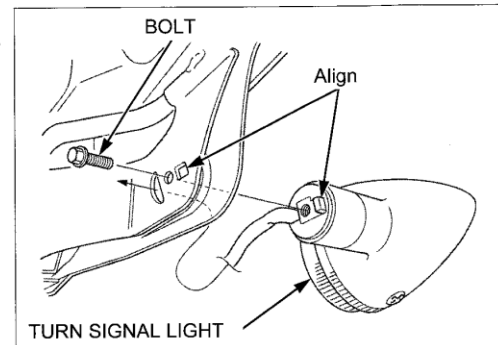

BRAKE/TAIL LIGHT

INSPECTION

Turn the ignition switch ON, and check the tail light operation.

Check that all LEDs in the brake/tail light unit illuminate with the front brake lever and/or rear brake pedal applied.

If any LED does not turn on, replace the brake/tail light assembly.

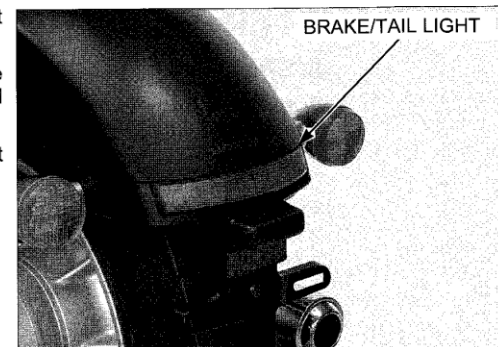

REMOVAL/INSTALLATION

Remove the rear fender (page 3-8).

Remove the brake/tail light 3P (Natural) connector from the rear fender A and disconnect it.

Remove the bolts and brake/tail light unit by releasing its tabs from the grommets of the rear fender A.

Remove the collars and grommets from the brake/tail light unit.

Installation is in the reverse order of removal.

TORQUE:

Brake/tail light mounting bolt:
5.2 N·m (0.5 kgf·m, 3.8 lbf·ft)

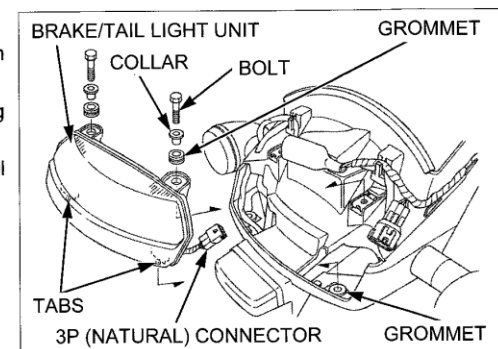

LICENSE LIGHT

BULB REPLACEMENT

Remove the screws and license light cover.

Remove the bulb and replace it with a new one.

Make sure the cover packing is installed in position and is in good condition, and replace it with a new one if necessary.

Installation is in the reverse order of removal.

TORQUE:

License light lens screw:

1 N·m (0.1 kgf·m, 0.7 lbf·ft)

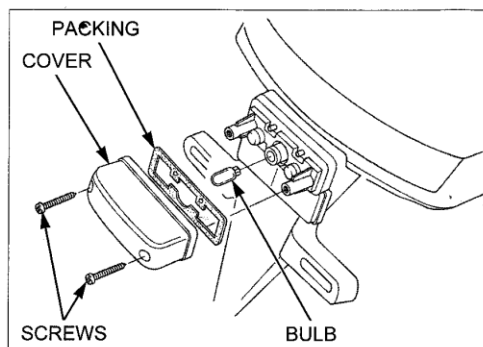

REMOVAL/INSTALLATION

Remove the rear fender (page 3-8).

Disconnect the license light 2P (White) connector.

Release the license light wire from the hole of the rear fender A.

Remove the nuts, collars and license light unit.

Installation is in the reverse order of removal.

TORQUE:

License light mounting nut:

4.5 N·m (0.5 kgf·m, 3.3 lbf·ft)

Route the wire properly (page 1-22).

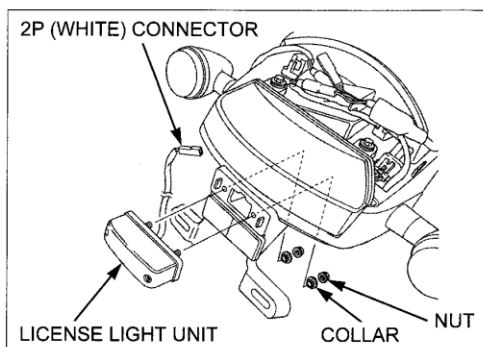

SPEEDOMETER

INSPECTION

When the ignition switch turns ON, check that the speedometer needle moves to full scale and then returns to zero.

If the speedometer needle does not show initial function, perform the power and ground line inspection of the speedometer.

If the speedometer needle shows initial function but speedometer does not move at running, check the system inspection (page 22-12).

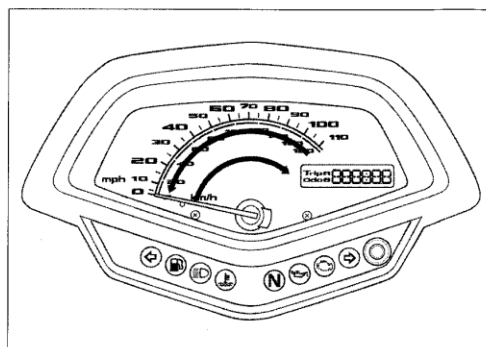

Remove the speedometer lower covers (page 22-12).

NOTE:

- Check the following at the speedometer sub-harness side connector of the speedometer.
- Do not disconnect the speedometer 20P (Gray) connector during inspection.
- After inspection, reposition the dust cover securely.

Remove the dust cover.

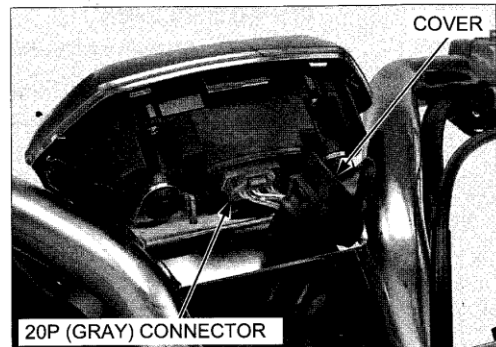

POWER INPUT LINE

Measure the voltage between the speedometer 20P (Gray) connector and ground.

CONNECTION: Brown (+) – Ground (-)

There should be battery voltage with the ignition switch turned ON.

If there is no battery voltage, check the following:

- Open circuit in the Brown wire
- Blown sub fuse 10 A (METER ILLUMI)

SPEEDOMETER 20P CONNECTOR

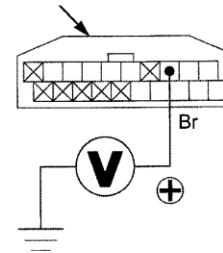

GROUND LINE

Check for continuity between the speedometer 20P (Gray) connector and ground.

CONNECTION: Green – Ground

There should be continuity at all times.

If there is no continuity, check for an open circuit in the Green wire.

SPEEDOMETER 20P CONNECTOR

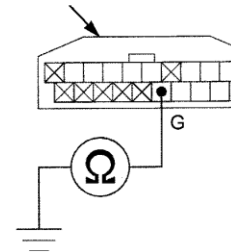

BACK-UP VOLTAGE LINE

Check this line if the odometer/trip meter does not function.

Measure the voltage between the speedometer 20P (Gray) connector and ground.

CONNECTION: Pink (+) – Ground (-)

There should be battery voltage at all times.

If there is no battery voltage, check the following:

- Open circuit in the Pink wire
- Blown sub fuse 10 A (CLOCK)

SPEEDOMETER 20P CONNECTOR

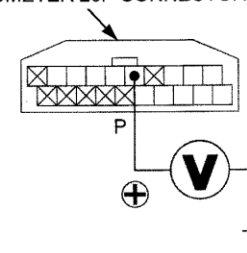

LIGHTS/METERS/SWITCHES

SYSTEM INSPECTION

Shift the transmission into neutral.

Turn the ignition switch ON and engine stop switch "O".

Measure the voltage between the Speedometer 20P (Gray) connector.

CONNECTION: Green/yellow (+) – Green/black (-)

Slowly turn the rear wheel by hand.
There should be 0 V to 5 V pulse voltage.

If pulse voltage appears, replace the speedometer.

If pulse voltage does not appear, check the following:

- Green/yellow wire for an open or short circuit
 - Green/black wire for an open circuit
- If the wires are OK, check the VS sensor (page 22-14).

SPEEDOMETER 20P CONNECTOR

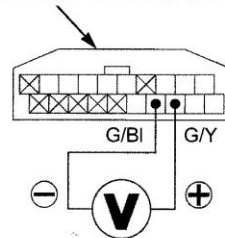

REMOVAL/INSTALLATION

Remove the socket bolts, fixing clips and speedometer rear lower cover.

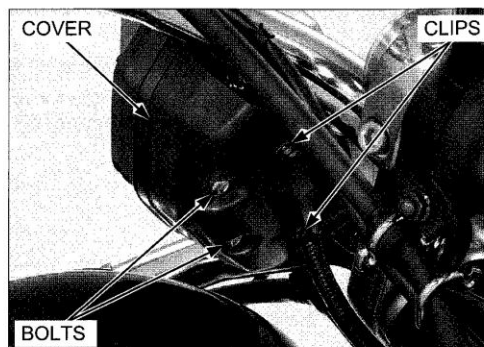

Remove the socket bolt and speedometer front lower cover.

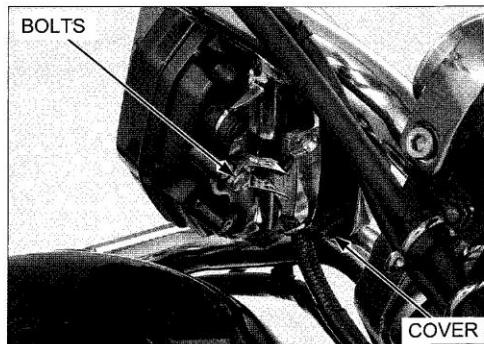

Remove the dust cover and disconnect the speedometer 20P (Gray) connector.

Remove the following:

- Screws
- Washers
- Grommets
- Speedometer

Installation is in the reverse order of removal.

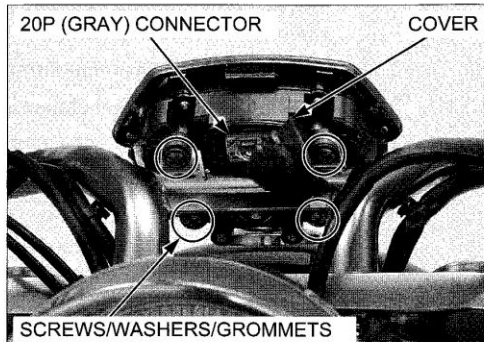

DISASSEMBLY

Remove the screws and upper cover.

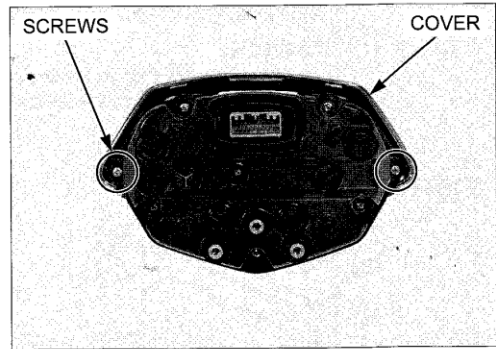

Remove the screws and under case.

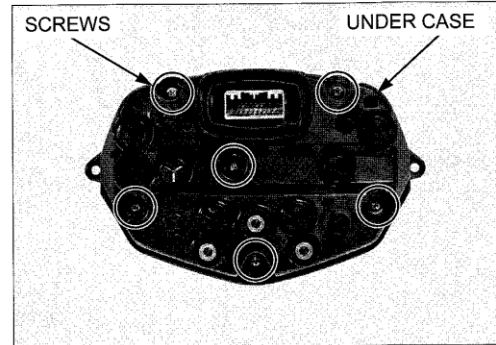

Remove the circuit assembly from the upper case.

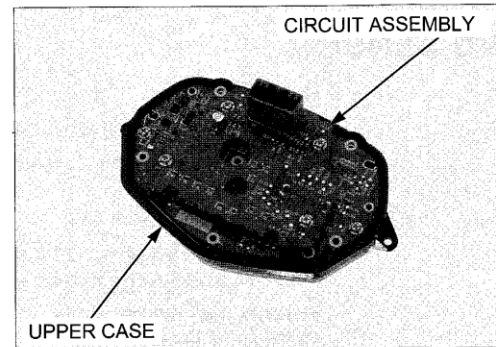

LIGHTS/METERS/SWITCHES

ASSEMBLY

Assembly is in the reverse order of disassembly.

TORQUE:

Speedometer upper cover screw:
1 N·m (0.1 kgf·m, 0.7 lbf·ft)

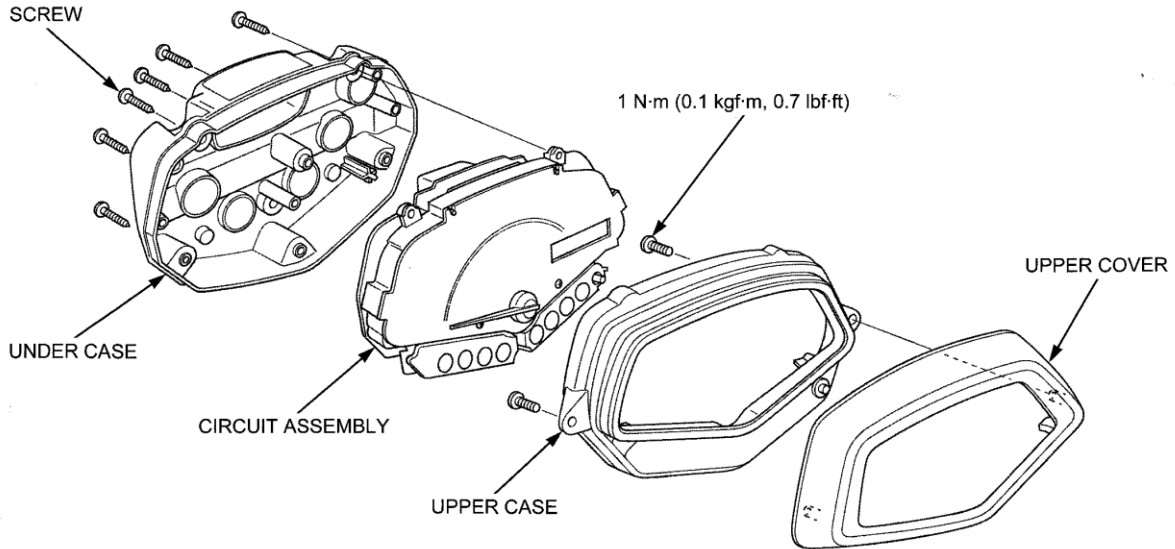

VS SENSOR

INSPECTION

Remove the rear fender (page 3-8).

Check for loose or poor contact of the VS sensor 3P (Black) connector.

Turn the ignition switch OFF.

Disconnect the VS sensor 3P (Black) connector.

Turn the ignition switch ON and engine stop switch "O".

Measure the voltage at the VS sensor 3P (Black) connector of the wire side.

CONNECTION: Green/yellow (+) – Green/black (-)

STANDARD: 4.8 – 5.8 V

If there is no voltage, check for an open or short circuit in Green/yellow or in Green/black wire.

Turn the ignition switch OFF and disconnect the ECM 33P (Gray) connector (page 6-62).

Check for continuity between the VS sensor 3P (Black) and ECM 33P (Gray) connectors of the wire side.

CONNECTION: B28 – Green/yellow

Tool:

Test probe

07ZAJ-RDJA110

There should be continuity.

If there is no continuity, check for open circuit in Green/yellow wire.

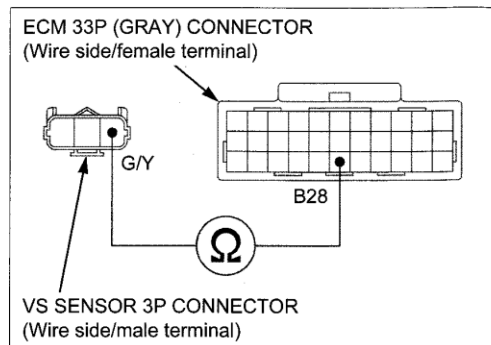
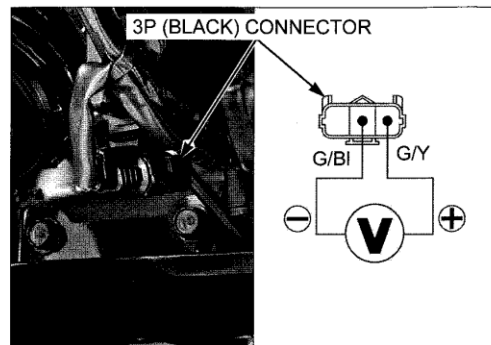

Check for continuity between the VS sensor 3P (Black) connector of the wire side and ground.

CONNECTION: Green/yellow – Ground

There should be no continuity.

If there is continuity, check for short circuit in Green/yellow wire.

VS SENSOR 3P CONNECTOR
(Wire side/male terminal)

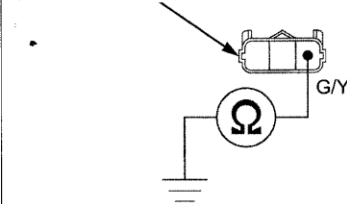

REMOVAL/INSTALLATION

Remove the engine (page 8-4).

Remove the bolts and VS sensor from the crankcase.

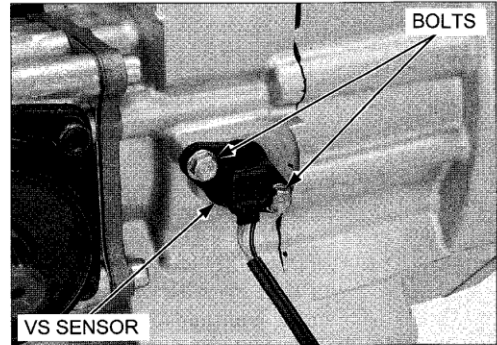

Remove the O-ring from the VS sensor.

Apply engine oil to a new O-ring and install it to the VS sensor.

Install the VS sensor to the crankcase.

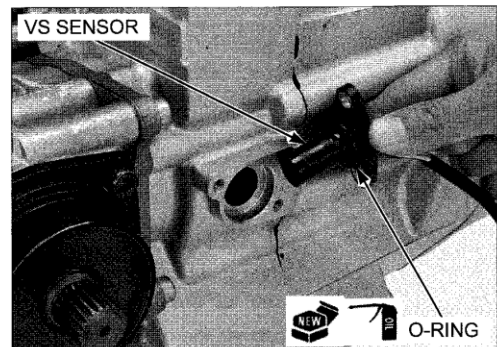

Install and tighten the VS sensor mounting bolts to the specified torque.

TORQUE: 10 N·m (1.0 kgf·m, 7 lbf·ft)

Install the engine (page 8-10).

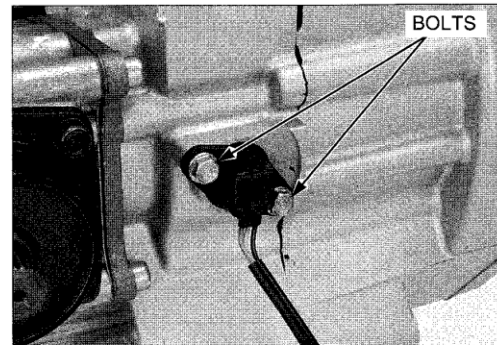

COOLANT TEMPERATURE INDICATOR/ECT SENSOR

INSPECTION

The coolant temperature is too high, but the indicator does not come on.

Check that the neutral and oil pressure indicators function properly.

If they do not function, check the power input line of the speedometer (page 22-10).

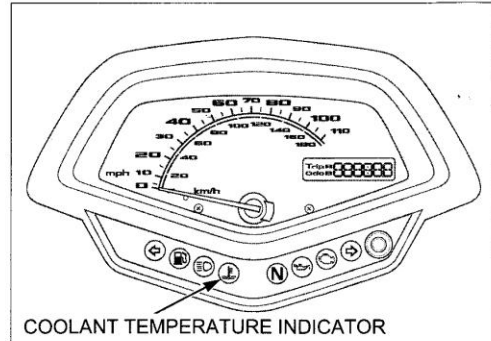

Remove the following:

- Ignition switch (page 22-20)
- Rear left over head cover (page 3-5)

Disconnect the ECT sensor 3P (Gray) connector. Ground the Green/white wire of the ECT sensor 3P (Gray) connector with a jumper wire.

Turn the ignition switch ON and check the coolant temperature indicator.

If the indicator comes on, inspect the ECT sensor (page 22-17).

If the indicator does not come on, check for an open circuit in the Green/white wire. If the wire is OK, replace the speedometer circuit assembly (page 22-12).

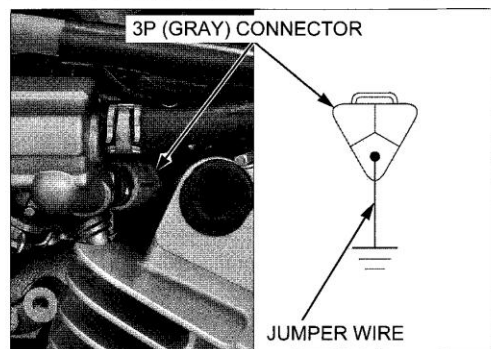

The coolant temperature is low but the indicator comes on.

Remove the following:

- Ignition switch (page 22-20)
- Rear left over head cover (page 3-5)

Disconnect the ECT sensor 3P (Gray) connector.

Turn the ignition switch ON and check the coolant temperature indicator.

If the indicator does not come on, inspect the ECT sensor (page 22-17).

If the indicator comes on, check for a short circuit in the Green/white wire. If the wire is OK, replace the speedometer circuit assembly (page 22-12).

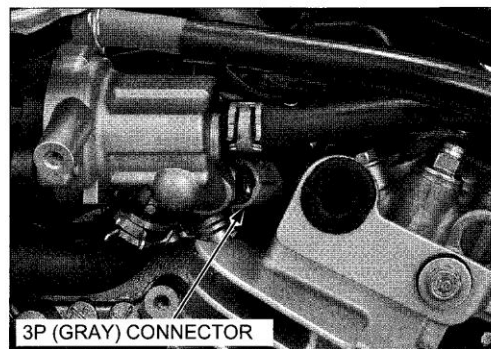

ECT SENSOR INSPECTION

Drain the coolant from the system (page 7-7).
Remove the ECT sensor (page 6-58).

Wear insulated gloves and adequate eye protection. Keep flammable materials away from the burner.

Heat the coolant (1:1 mixture) with an electric heating element.
Suspend the ECT sensor in heated coolant and check for continuity through the sensor as the coolant heats up.

NOTE:

- Soak the ECT sensor in coolant up to its threads with at least 40 mm (1.6 in) from the bottom of the pan to the bottom of the sensor.
- Keep temperature constant for 3 minutes before testing. A sudden change of temperature will result in incorrect readings. Do not let the thermometer or ECT sensor touch the pan.

Temperature	50°C (122°F)	80°C (176°F)
Resistance	6.8 – 7.4 kΩ	2.1 – 2.7 kΩ

Replace the ECT sensor if it is out of specifications.
Install the ECT sensor (page 6-58).

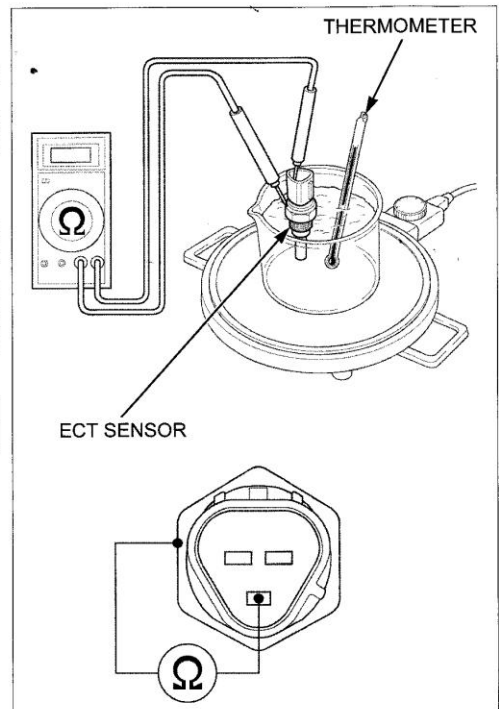

FUEL RESERVE SENSOR

INSPECTION

Fuel tank is empty, but the indicator does not come on

Check that the neutral and oil pressure indicators function properly.

If they do not function, check the power input line of the speedometer (page 22-10).

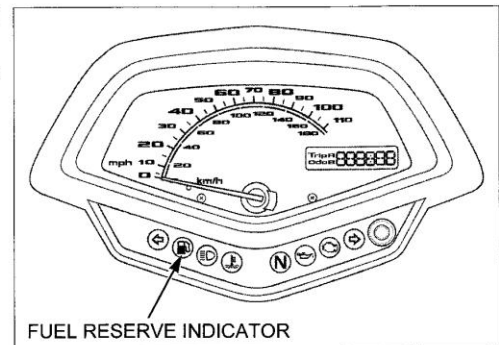

Remove the fuel tank (page 6-43).

Jump the Light green and Green wire terminals of the wire harness side using a jumper wire.

Turn the ignition switch ON and check the fuel reserve indicator.

If the indicator comes on, replace the fuel reserve sensor (page 22-18).

If the indicator does not come on, check for open circuit in Light green wire.

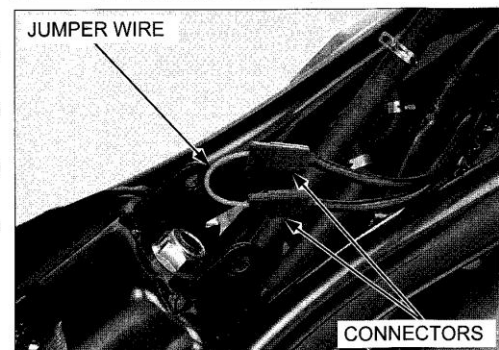

LIGHTS/METERS/SWITCHES

Enough fuel left in the fuel tank, but the indicator stays on

Remove the fuel tank (page 6-43).

Disconnect the fuel reserve sensor connectors.

Check for continuity between the Light green wire and body ground.

If there is continuity, check for short circuit in Light green wire.

If there is no continuity, replace the fuel reserve sensor (page 22-18).

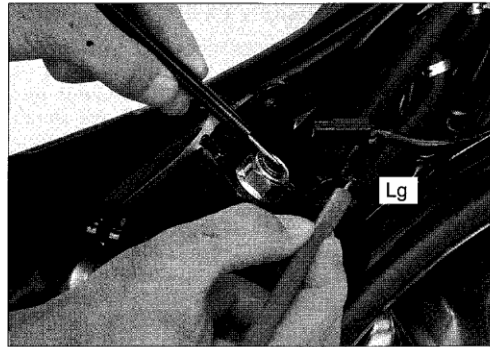

REMOVAL/INSTALLATION

Remove the fuel tank (page 6-43).

Drain the fuel into an approved fuel container.

Remove the fuel reserve sensor and O-ring.

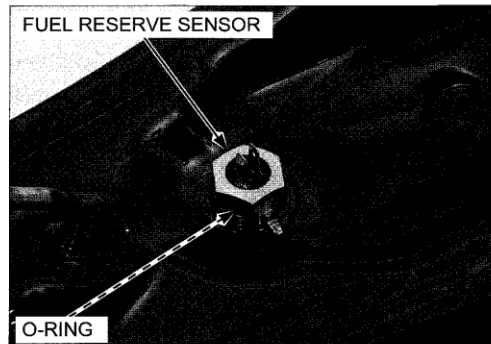

Install a new O-ring onto the fuel reserve sensor and install them to the fuel tank.

Tighten the fuel reserve sensor to the specified torque.

TORQUE: 23 N·m (2.3 kgf·m, 17 lbf·ft)

Install the fuel tank (page 6-43).

NOTE:

- After installing the fuel tank, check that there is no fuel leak.

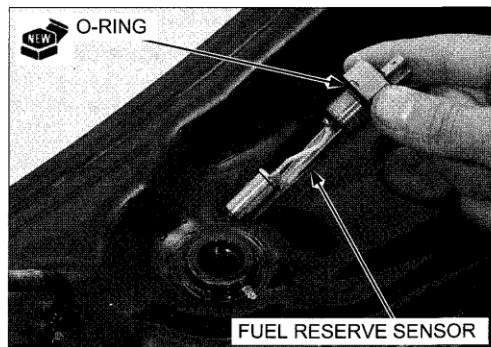

OIL PRESSURE INDICATOR

INSPECTION

Indicator does not light with the ignition switch turned ON

- Before starting the inspection, check for loose or poor contact on the EOP switch 1P (Black) connector.

Check that the speedometer indicators function properly.

If they do not function properly, check the power input line of the speedometer (page 22-10).

Remove the exhaust system (page 3-10).

Remove the rubber cap and disconnect the EOP switch wire by removing the terminal screw.

Ground the terminal of the EOP switch to the engine with a jumper wire.

Turn the ignition switch ON and check the oil pressure indicator.

If the indicator comes on, replace the EOP switch.

If the indicator does not come on, check for loose or poor connections, or an open circuit in the Blue/red wire.

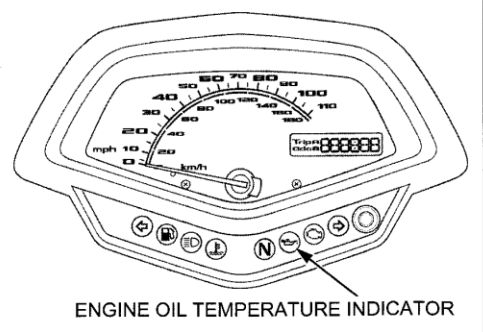
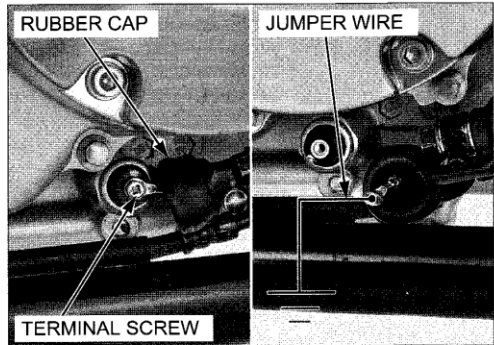

Indicator stays lit while the engine is running

- Before starting the inspection, check for loose or poor contact on the EOP switch 1P (Black) connector.

Remove the exhaust system (page 3-10).

Remove the rubber cap and disconnect the EOP switch wire by removing the terminal screw.

Check for continuity between the terminal of the EOP switch and ground.

If there is continuity, check for a short circuit in the Blue/red or Black wire.

If there is no continuity, check the oil pressure (page 5-5).

If the oil pressure is normal, replace the EOP switch (page 5-5).

After inspection, connect the EOP switch wire by installing the terminal screw.

Tighten the terminal screw to the specified torque.

TORQUE: 2.2 N·m (0.2 kgf·m, 1.6 lbf·ft)

Reposition the rubber cap securely.

Install the exhaust system (page 3-17).

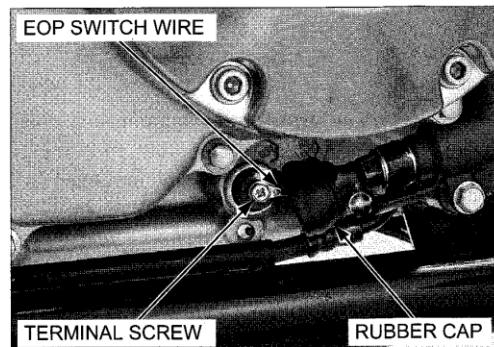
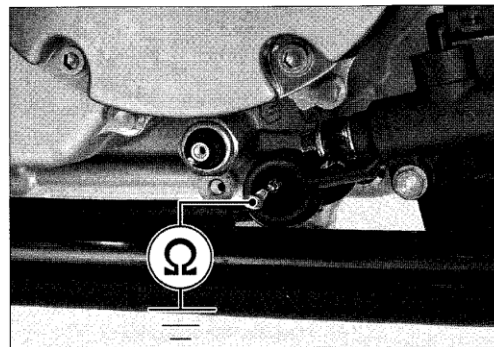

IGNITION SWITCH

INSPECTION

Remove the fuel tank (page 6-43).
 Disconnect the ignition switch 2P (Black) connector.
 Check for continuity between the switch side connector terminals in each switch position.
 Continuity should exist between the color coded wires as shown in the chart.

	IG	BAT1
ON	○	○
OFF		
COLOR	R/BI	R

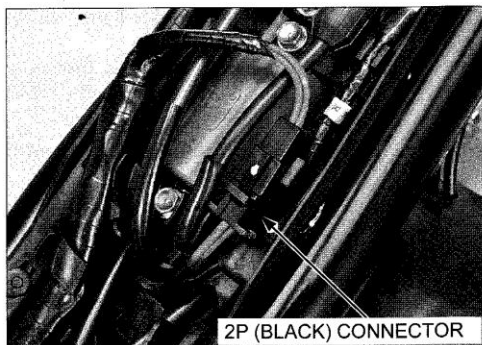

REMOVAL/INSTALLATION

Remove the following:

- Remove the fuel tank (page 6-43)
- Ignition switch case (page 3-10)
- Front center over head cover (page 3-5)

Disconnect the ignition switch 2P (Black) connector.
 Remove the wire band.

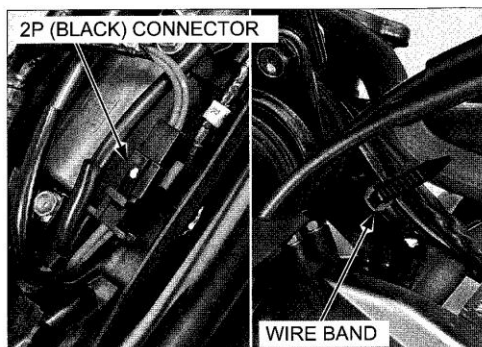

Remove the socket bolts, bolt and ground wire.

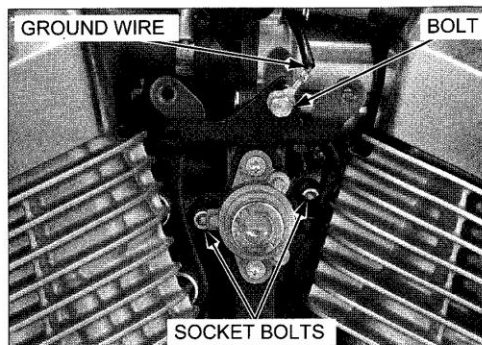

Remove the following:

- Torx bolts
- Ignition switch
- Collar
- Base rubber
- Stay

Route the wire properly (page 1-22).

Installation is in the reverse order of removal.

TORQUE:
 Ignition switch mounting torx bolt:
 10 N·m (1.0 kgf·m, 7 lbf·ft)

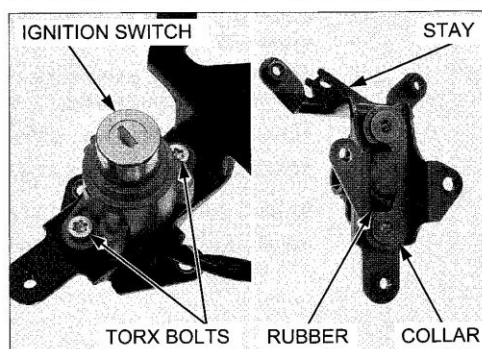

HANDLEBAR SWITCH

Remove the headlight unit (page 22-5).
 Remove the handlebar switch connectors from the stay.
 Disconnect the right handlebar switch 8P (White) connector and left handlebar switch 14P (White) connector.
 Check for continuity between the connector terminals in each switch position.
 Continuity should exist between the color coded wires as shown in the charts.

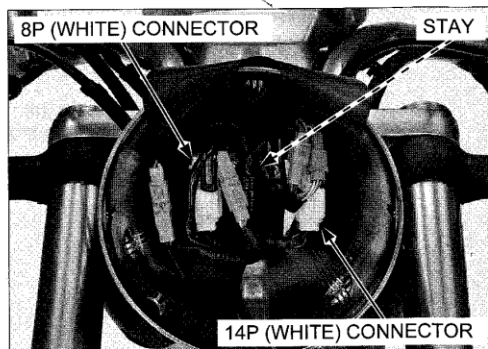

RIGHT HANDLEBAR SWITCH

ENGINE STOP SWITCH

	BAT2	IG
	○—○	○—○
COLOR	W/BI	BI/W

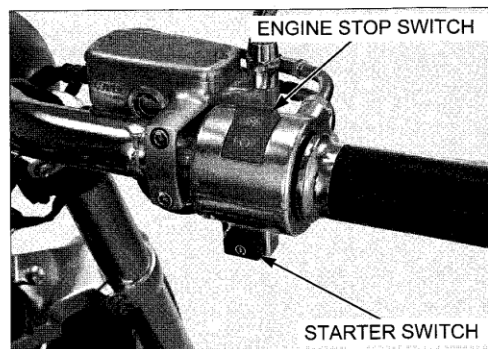

STARTER SWITCH

	IG	ST	BAT1	HL
FREE			○—○	
PUSH	○—○	○—○		
COLOR	BI/W	Y/R	BI/R	Bu/W

LEFT HANDLEBAR SWITCH

DIMMER SWITCH

	HL	Lo	Hi
	○—○		
(N)	○—○—○		
	○—○—○		
COLOR	Bu/W	W	Bu

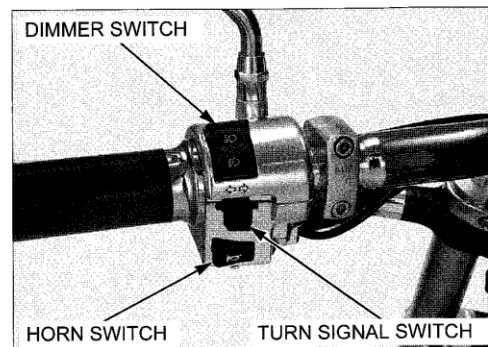

TURN SIGNAL SWITCH

	W	R	L	PO	PR	PL
	○—○			○—○—○		
N				○—○—○		
	○—○		○—○	○—○		
COLOR	Gr	Lb	O	BI/Br	Lb/W	O/W

HORN SWITCH

	Ho	BAT3
FREE		
PUSH	○—○	
COLOR	Lg	W/G

BRAKE LIGHT SWITCH

FRONT

Disconnect the front brake light switch connectors and check for continuity between the switch terminals.

There should be continuity with the front brake lever squeezed and no continuity with the lever released.

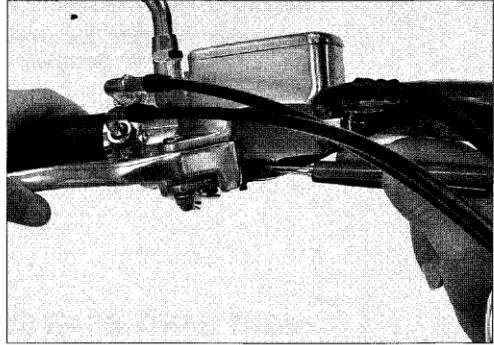

REAR

Remove the socket bolt and reservoir cover.

Disconnect the rear brake light switch 2P (Gray) connector while moving the reservoir.

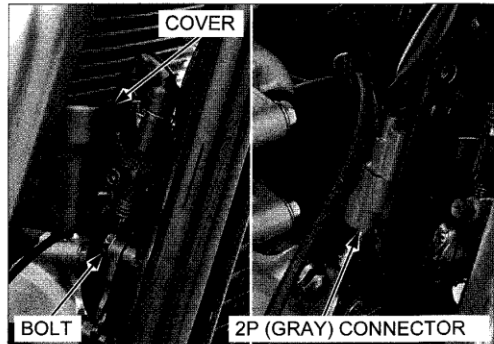

Check for continuity between the switch side connector terminals.

There should be continuity with the rear brake pedal depressed and no continuity with the pedal released.

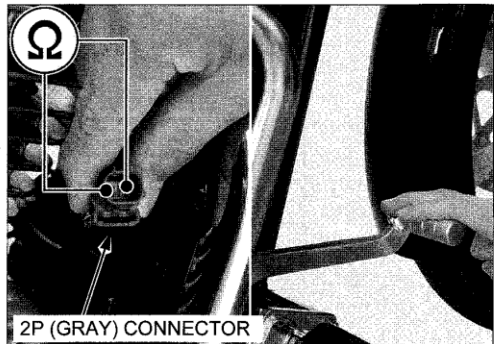

**REAR BRAKE LIGHT SWITCH
REMOVAL/INSTALLATION**

Remove the socket bolt and reservoir cover.

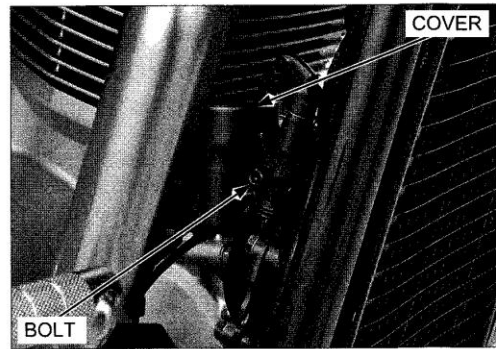

Disconnect the rear brake light switch 2P (Gray) connector while moving the reservoir.

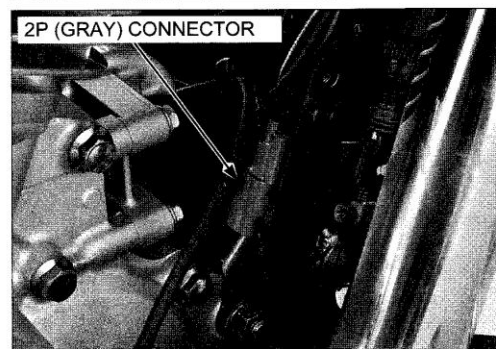

Remove the clamp from the stay.

Unhook the return spring and remove the rear brake light switch.

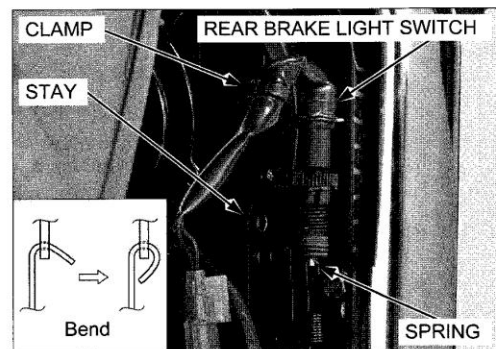

Route the wire properly (page 1-22).

Installation is in the reverse order of removal.

NOTE:

- After hooking the return spring, bend the return spring tip.

Adjust the rear brake light switch (page 4-23).

CLUTCH SWITCH

Disconnect the clutch switch wire connectors and check for continuity between the switch terminals.

There should be continuity with the clutch lever squeezed and no continuity with the lever released.

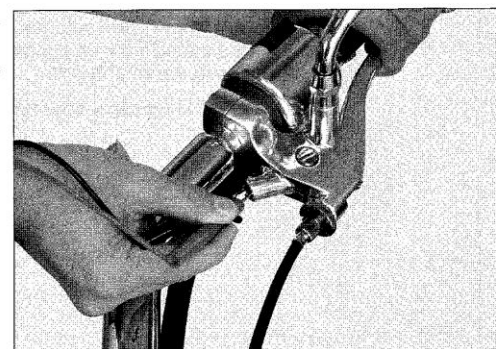

NEUTRAL SWITCH

INSPECTION

Remove the left crankcase rear cover (page 3-7).

Disconnect the neutral switch wire connector.

Check for continuity between the switch terminal and engine ground.

There should be continuity when the transmission is in neutral, and no continuity when the transmission is in gear.

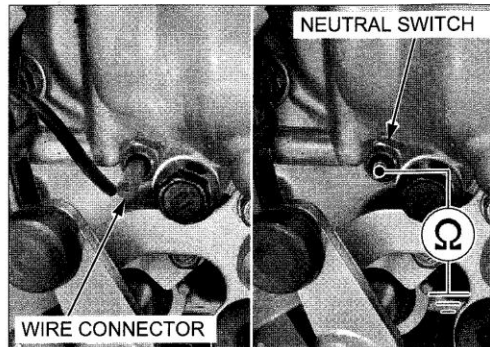

REMOVAL/INSTALLATION

Remove the left crankcase rear cover (page 3-7).

Remove the bolt and gearshift arm from the gearshift spindle.

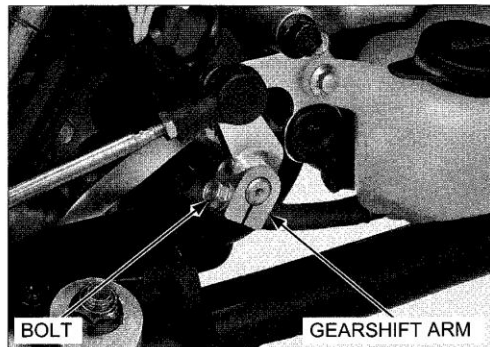

Disconnect the neutral switch wire connector.

Remove the neutral switch from the crankcase.

Install the neutral switch with a new sealing washer and tighten it to the specified torque.

TORQUE: 12 N·m (1.2 kgf·m, 9 lbf·ft)

Connect the neutral switch wire connector.

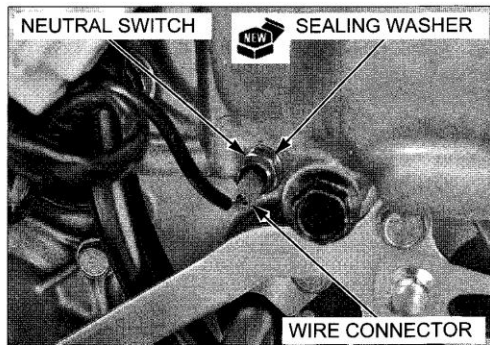

Install the gearshift arm onto the spindle by aligning its slit with the punch mark on the gearshift spindle. Tighten the gearshift arm bolt.

Install the left crankcase rear cover (page 3-7).

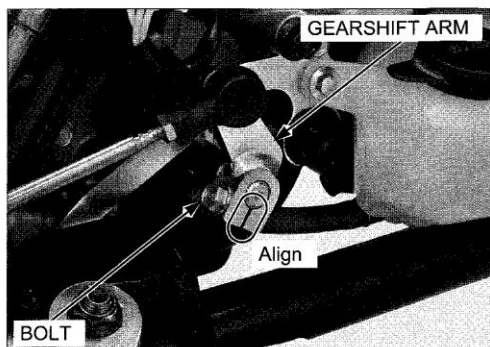

SIDESTAND SWITCH

INSPECTION

Remove the left crankcase rear cover (page 3-7).
 Disconnect the sidestand switch 2P (Gray) connector.
 Check for continuity between the switch side connector terminals.
 There should be continuity with the sidestand retracted and no continuity with the sidestand lowered.

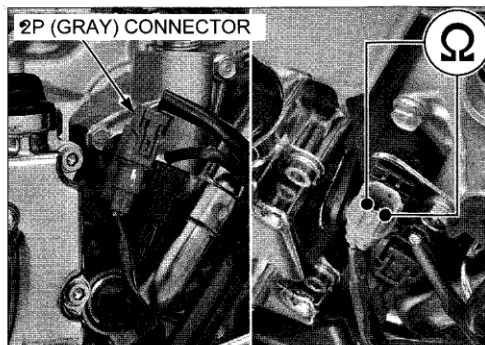

REMOVAL/INSTALLATION

Support the motorcycle using a safety stand or hoist.
 Remove the left crankcase rear cover (page 3-7).
 Disconnect the sidestand switch 2P (Gray) connector and remove it to the water pipe stay.
 Remove the clamp.

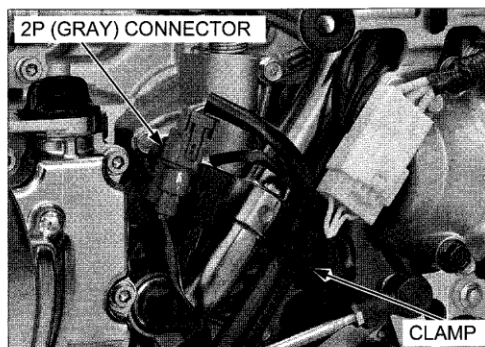

Do not reuse the bolt. Remove the bolt and sidestand switch.

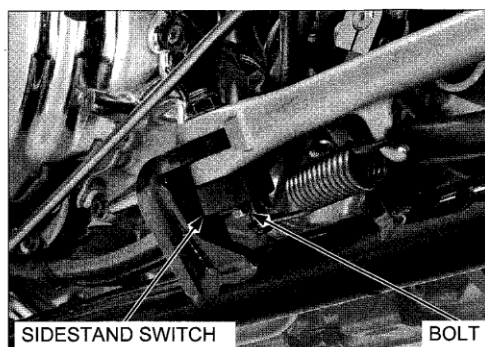

Install the sidestand switch by aligning the following:

- Switch pin and sidestand hole
- Switch groove and spring hook pin

Install and tighten a new sidestand switch bolt to the specified torque.

TORQUE: 10 N·m (1.0 kgf·m, 7 lbf·ft)

Route the sidestand switch wire properly (page 1-22).

Connect the sidestand switch 2P (Gray) connector.

Install the left crankcase rear cover (page 3-7).

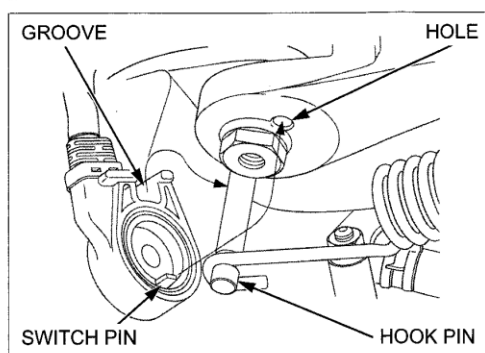

HORN

INSPECTION

Disconnect the connectors from the horn.

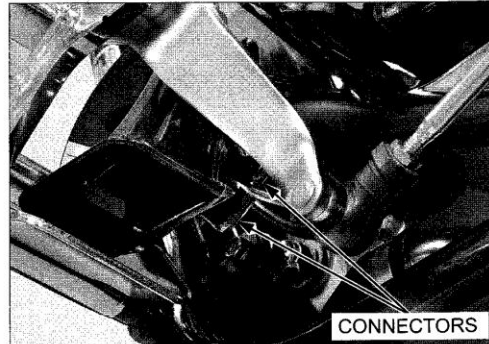

Connect a 12 V battery to the horn terminals.

The horn is normal if it sounds when the 12 V battery is connected to the horn terminals.

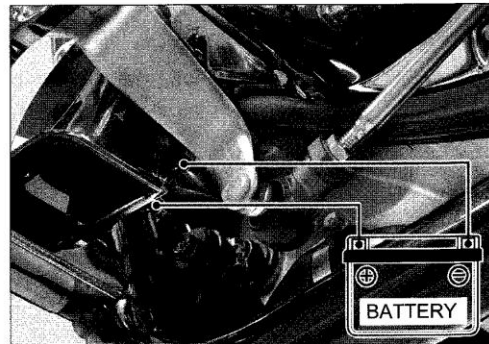

REMOVAL/INSTALLATION

Disconnect the connectors from the horn.

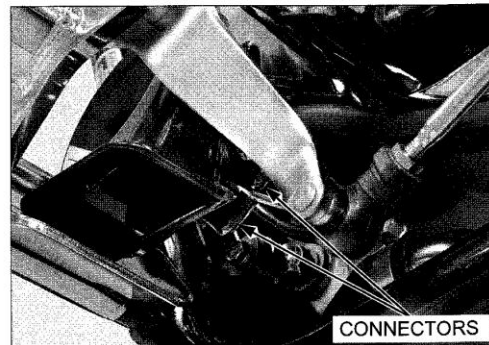

Remove the bolt, nut and horn.

Install the horn to the frame, aligning its flat with the horn stay.

Install and tighten the bolt to the specified torque.

TORQUE: 27 N·m (2.8 kgf·m, 20 lbf·ft)

Connect the connectors.

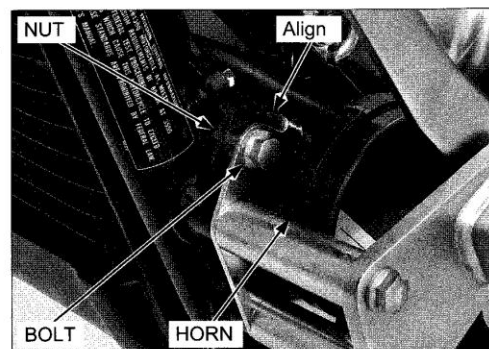

TURN SIGNAL RELAY

INSPECTION

Remove the rear fender (page 3-8).

1. Related Circuit Inspection

Check the following:

- Battery condition
- Burned out bulb or non-specified wattage
- Blown main fuse 30 A and sub fuse 10 A (TURN/HORN)
- Ignition switch and turn signal switch function
- Loose connectors
 - Turn signal relay 3P (Black) connector
 - Left handlebar switch 14P (White) connector
 - Ignition switch 2P (Black) connector
 - Starter relay switch 4P (Red) connector

Are the above items in good condition?

YES – GO TO STEP 2.

NO – Replace or repair the malfunction part(s).

2. Turn Signal Circuit Inspection

Disconnect the turn signal relay 3P (Black) connector.

Short the turn signal relay 3P (Black) connector terminals of the wire harness side using a jumper wire.

Turn the ignition switch ON and check the turn signal light by moving the turn signal switch all the way in the right side or left side.

Does the light come on?

YES – • Faulty turn signal relay
• Poor connection of the connector

NO – Open circuit in the wire harness

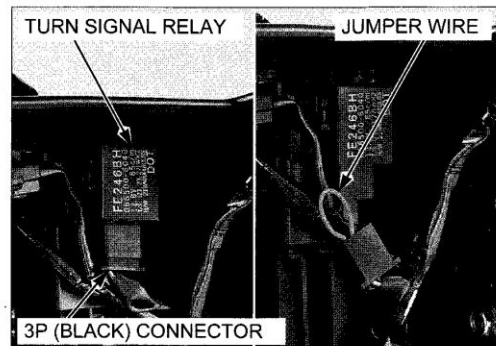

REMOVAL/INSTALLATION

Remove the rear fender (page 3-8).

Disconnect the turn signal relay 3P (Black) connector.

Remove the turn signal relay.

Installation is in the reverse order of removal.



MEMO

